

**KENDRIYA VIDYALAYA SANGATHAN, HYDERABAD REGION**  
**SAMPLE PAPER 07 (2017-18)**

SUBJECT: SCIENCE (086)

**BLUE PRINT : CLASS X**

UNIT	Chapter	VSA (1 mark)	SA – I (2 marks)	SA – II (3 marks)	LA (5 marks)	Practical Based Questions	Total	Unit Total
Chemical Substances - Nature and Behaviour	Chemical Reactions and Equations	--	--	3(1)	--	--	3(1)	25(8)
	Acids, Bases and Salts	--	--	3(1)*	--	2(1)	5(2)	
	Metals and Non-metals	--	--	--	5(1)	--	5(1)	
	Carbon and its compounds	--	--	--	5(1)*	2(1)	7(2)	
	Periodic Classification of Elements	--	2(1)	3(1)	--	--	5(2)	
World of Living	Life Process	--	--	3(1)*	--	2(1)	5(2)	23(9)
	Control and Coordination	1(1)	--	--	5(1)	--	8(3)	
	How do organisms reproduce?	1(1)	--	3(1)	--	2(1)	4(2)	
	Heredity and Evolution	--	--	6(2)	--	--	6(2)	
Natural Phenomena <sup>a</sup>	Light - Reflection and Refraction	--	2(1)	3(1)	--	2(1)	7(3)	12(4)
	The Human Eye and the colourful world	--	--	--	5(1)	--	5(1)	
Effects of Current	Electricity	--	--	3(1)	--	2(1)	5(2)	13(4)
	Magnetic Effects of Electric Current	--	--	3(1)*	5(1)	--	8(2)	
Natural Resources	Sources of energy	--	2(1)	--	--	--	2(1)	7(2)
	Our Environment	--	--	--	5(1) <sup>#</sup>	--	5(1)	
	Management of Natural Resources	--	--	--		--		
	<b>Total</b>	<b>2(2)</b>	<b>6(3)</b>	<b>30(10)</b>	<b>30(6)</b>	<b>12(6)</b>	<b>80(27)</b>	<b>80(27)</b>

Note: \* - Internal Choice Questions of same chapter.

# - Internal Choice Questions of two chapters

**KENDRIYA VIDYALAYA SANGATHAN, HYDERABAD REGION**  
**SAMPLE PAPER 07 (2017-18)**

**SUBJECT: SCIENCE**  
**CLASS : X**

**MAX. MARKS : 80**  
**DURATION : 3 HRS**

**General Instructions:**

1. All questions are compulsory.
2. The question paper comprises of **two Sections, A and B**. You are to attempt both the sections.
3. All questions of **Section-A** and **Section-B** are to be attempted separately.
4. There is an internal choice in three questions of three marks each and two question of five marks.
5. Question number **1 to 2** in **Section-A** are **one mark** question. These are to be answered in **one word** or in **one sentence**.
6. Question numbers **3 to 5** in **Section-A** are **two marks** questions. These are to be answered in about **30 words** each.
7. Question numbers **6 to 15** in **Section-A** are **three marks** questions. These are to be answered in about **50 words** each.
8. Question numbers **16 to 21** in **Section-A** are **five marks** questions. These are to be answered in about **70 words** each.
9. Question numbers **22 to 27** in **Section-B** are questions based on practical skills and are **two marks** questions.

**SECTION – A**

1. Mention any one point of difference between Pepsin and Trypsin.
2. Give an example of a flower which contains both stamens and carpels.
3. Why is there a need to harness non-conventional sources of energy? Give two main reasons.
4. An element “X” has mass number 35 and the number of neutrons, is 18. Identify the group number and period of “X”.
5. An object is kept in front of a concave mirror of focal length 20 cm. The image is three times the size of the object. Calculate two possible distances of the object from the mirror.
6. Give scientific reasons.
  - (a) Wires carrying electricity should not be touched when bare-footed.
  - (b) We must not use many electrical appliances simultaneously.
  - (c) Electrical switches should not be operated with wet hand.

**OR**

State one main difference between AC and DC. Why AC is preferred over DC for long range transmission of electric power? Name one source each of DC and AC.

7. A circuit is shown in the diagram given below.

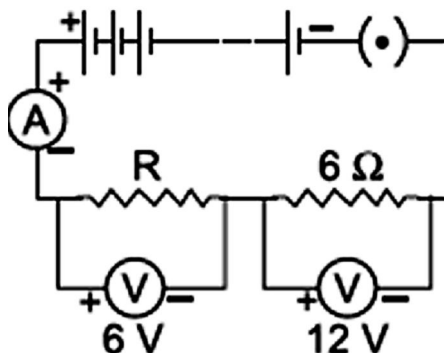

- (a) Find the value of R.
- (b) Find the reading of the ammeter.
- (c) Find the potential difference across the terminals of the battery.

8. What is meant by:

- (a) Displacement reaction
- (b) Reduction reaction
- (c) Combination reaction.

Write balanced chemical equation for each reaction:

9. How many groups and periods are there in the Modern Periodic Table? How do the atomic size and metallic character of elements vary as we move: (i) down a group and (ii) from left to right in a period
10. (a) Describe the mechanism of breathing in human beings.  
(b) (i) Under normal conditions, what is the rate of breathing per minute?  
(ii) Why does the rate of breathing increase by 20 to 25 times during vigorous exercise?

**OR**

Write one function of each of the following components of the transport system in human beings: (a) Blood vessels (b) Lymph (c) Heart

11. Define 'evolution'. Describe Darwin's theory of evolution.
12. An object placed on a metre scale at 8 cm mark was focussed on a white screen placed at 92 cm mark, using a converging lens placed on the scale at 50 cm mark.  
(i) Find the focal length of converging lens.  
(ii) Find the position of the image formed if the object is shifted towards the lens at a position of 29.0 cm.  
(iii) State the nature of the image formed if the object is further shifted towards the lens.
13. (a) Write the name given to bases that are highly soluble in water. Give an example.  
(b) How is tooth decay related to pH? How can it be prevented?  
(c) Why does bee sting cause pain and irritation? Rubbing of baking soda on the sting area gives relief. How?

**OR**

- (a) Name the compound which is obtained from baking soda and is used to remove permanent hardness of water.
- (b) Write its chemical formula.
- (c) What happens when it is recrystallised from its aqueous solution?

14. Distinguish between homologous organs and analogous organs. In which category would you place wings of a bird and wings of a bat? Justify your answer giving a suitable reason.
15. A newspaper has recently published a survey result which says that number of AIDS patients in the country is increasing everyday. The report also says that awareness among people about AIDS is still very poor. You discussed the newspaper report with your friend and both of you decided to help people to fight against this deadly disease.  
(a) To which category of diseases AIDS belong? Name its causative organism.  
(b) What problem do you anticipate if both of you try to educate the people of your village?

16. With the help of a labelled circuit diagram wire describe an activity to illustrate the pattern of the magnetic field lines around a straight current carrying long conducting wire .
- Name the rule that is used to find the direction of magnetic field associated with a current carrying conductor.
  - Is there a similar magnetic field produced around a thin beam of moving (a) alpha particles and (b) neutrons? Justify your answer.
17. You are given balls and stick model of six carbon atoms and fourteen hydrogen atoms and sufficient number of sticks. In how many ways one can join the models of six carbon atoms and fourteen hydrogen atoms to form different molecules of  $C_6H_{14}$ .

**OR**

Draw the structural formulae of all the possible isomers of the compound with the molecular formula  $C_3H_6O$  and also give their electron dot structures.

18. a) Draw a neat diagram of human brain and label Medulla and Cerebellum. Write the functions of the above mentioned parts
- b) "Both overproduction and underproduction of Growth hormone leads to disorders in the body." Explain
19. Noopur needs a lens of power  $-4.5D$  for correction of her vision.
- What kind of defect in vision is she suffering from?
  - What is the focal length and nature of the corrective lens?
  - Draw ray diagrams showing the (a) defected eye and (b) correction for this defect.
  - What are the causes of this defect?
20. a) What is reactivity series? How does the reactivity series of metals help in predicting the relative activities of various metals?
- b) Suggest different chemical processes used for obtaining a metal from its oxides for metals in the middle of the reactivity series and metals towards the top of the reactivity series. Support your answer with one example each.
21. a) "Improvements in our lifestyle have resulted in greater amounts of waste generation." Give two examples to support the given statement. Suggest one change that we can incorporate in our lifestyle in order to reduce non-biodegradable waste.
- b) The following organisms form a food chain.  
Insect, Hawk, Grass, Snake, Frog  
Which of these will have highest concentration of non-biodegradable chemicals? Name the phenomenon.

**OR**

- What do you understand by "Watershed Management"? List any two advantages of watershed management.
- "Human beings occupy the top level in any food chain." What are the consequences of this on our body?

### **SECTION – B**

22. A solution 'X' gives orange colour when a drop of universal indicator is added to it. On the other hand, another solution 'Y' gives bluish-green colour when a drop of universal indicator is added to it. What are the types of solution 'X' and 'Y' and what type of pH would they have?
23. With the help of a suitable example explain in brief the process of hydrogenation mentioning the conditions for the reaction and also state any one physical property of substances which changes due to hydrogenation.

24. Draw a labelled diagram to show that particular stage of binary fission in Amoeba in which its nucleus elongates and divide into two and a constriction appears in its cell membrane.
25. What would happen if: (a) KOH solution is not hung in conical flask during experiment.  
(b) seeds are not kept moist during experiment.
26. A student focuses the image of a well-illuminated distant object on a screen using a convex lens. After that he gradually moves the object towards the lens and each time focuses its image on the screen by adjusting the lens.
- (i) In which direction-towards the screen or away from the screen, does he move the lens?
  - (ii) What happens to the size of the image-does it decrease or increase?
  - (iii) What happens to the image on the screen when he moves the object very close to the lens?
27. (i) Draw a schematic diagram of a circuit consisting of a cell of 1.5 V, 10  $\Omega$  and 15  $\Omega$  resistor and a plug key all connected in series.  
(ii) Which one is same in series, current or voltage ?

**OR**

Write two precautions that must be taken while determining the equivalent resistance of the two resistors when connected in series.

.....